

**HC** HYDRAULIC CRANE  
**INDUSTRIE**

## HC 370-R BC



I MIGLIORI PRODOTTI DI QUALITÀ | BEST QUALITY PRODUCTS

[www.hcindustrie.com](http://www.hcindustrie.com)

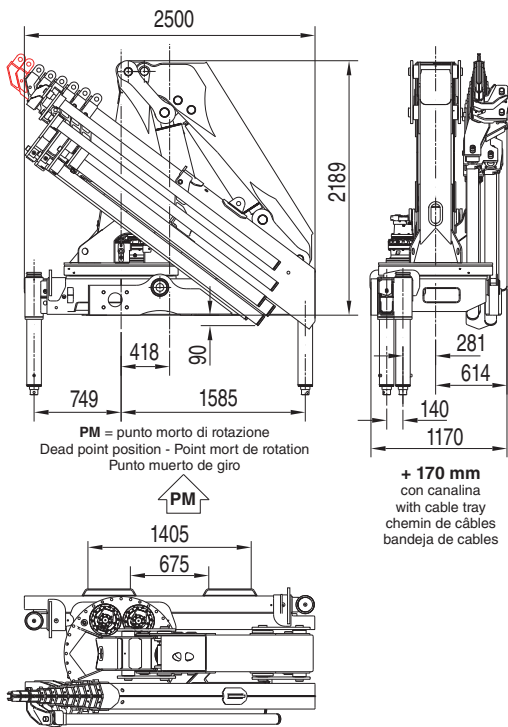

**GRU STANDARD Std Crane - Grue Standard - Grúa standard**

<b>Bracci stabilizzatori extra estensibili idraulici</b> Hydraulic extra extensible outrigger booms - Bras de stabilisation hydrauliques extra-extensibles - Brazos estabilizadores hidráulicos extra extensibles	<b>mm. 5540</b>
<b>Angolo di rotazione</b> Slewing angle - Angle de rotation - Giro	<b>400°</b>
<b>Tiranti di ancoraggio 42CrM04</b> Tie rods for anchorage - Tirants d'ancrage - Tirantes de fijación	<b>n° 8 M30x2</b>
<b>Portata raccomandata</b> Recommended oil flow - Débit recommandé - Caudal requerido	<b>l/min. 50</b>
<b>Capacità del serbatoio</b> Tank capacity - Capacité du réservoir - Capacidad del depósito de aceite	<b>lt. 160</b>
<b>Pressione massima</b> Rated pressure - Pression maxi - Presión máxima	<b>bar 340</b>

**HC 370-R BC A2**

<b>Massa della gru senza olio nel serbatoio</b> Overhang crane without oil in the tank Poids de la grue sans huile dans le réservoir Peso de la grúa sin aceite en el depósito	<b>Kg. 3860</b>
<b>Momento di sollevamento massimo</b> Maximum lifting moment - Moment de levage maxi Momento de elevación máxima	<b>tm 35,15</b>
<b>Sbraccio oleodinamico</b> Maximum hydraulic reach - Déport hydraulique - Alcance hidráulico	
<b>Orizzontale</b> Horizontal - Horizontal - Horizontal	<b>m. 6,55</b>
<b>Verticale</b> Vertical - Vertical - Vertical	<b>m. 10,05</b>

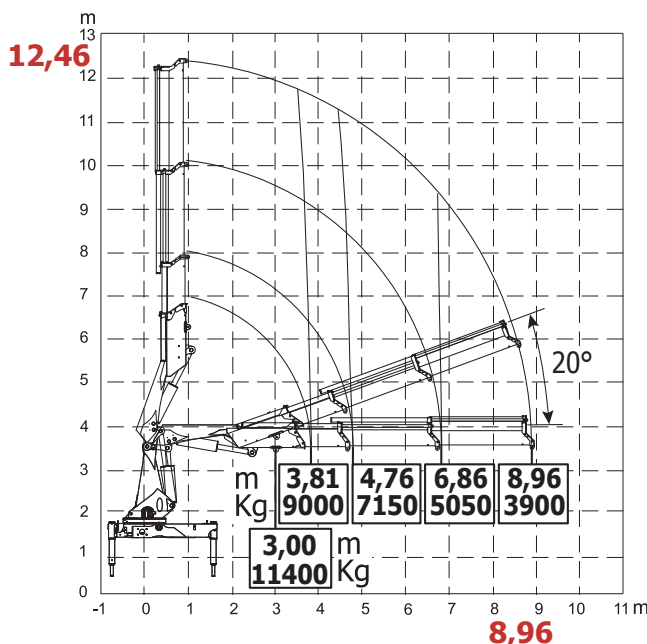
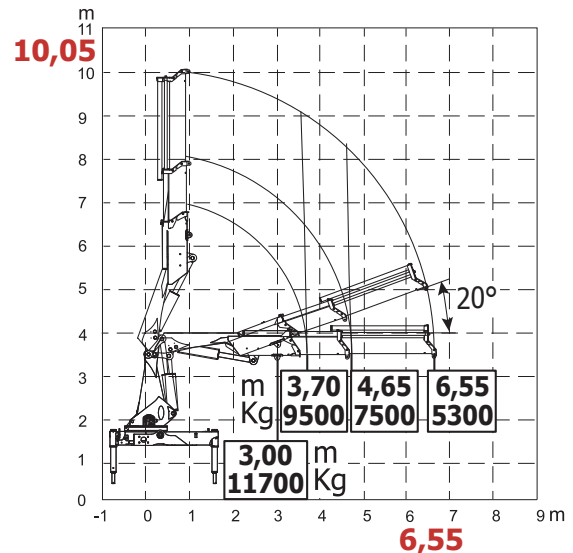

**HC 370-R BC A3**

<b>Massa della gru senza olio nel serbatoio</b> Overhang crane without oil in the tank Poids de la grue sans huile dans le réservoir Peso de la grúa sin aceite en el depósito	<b>Kg. 4100</b>
<b>Momento di sollevamento massimo</b> Maximum lifting moment - Moment de levage maxi Momento de elevación máxima	<b>tm 34,29</b>
<b>Sbraccio oleodinamico</b> Maximum hydraulic reach - Déport hydraulique - Alcance hidráulico	
<b>Orizzontale</b> Horizontal - Horizontal - Horizontal	<b>m. 8,96</b>
<b>Verticale</b> Vertical - Vertical - Vertical	<b>m. 12,46</b>

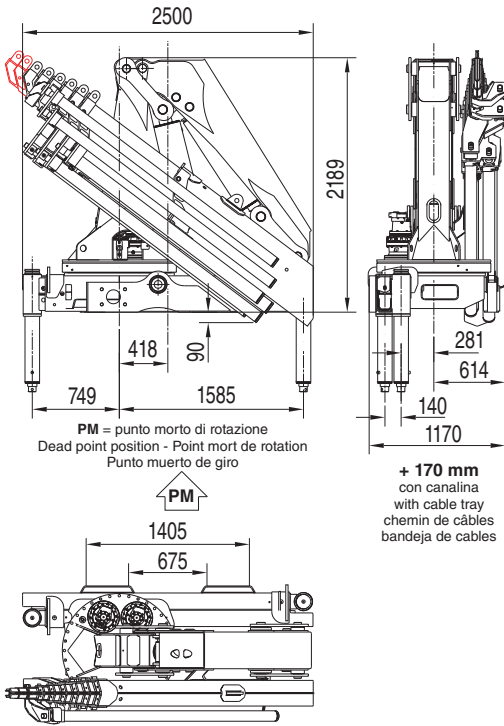

**GRU STANDARD Std Crane - Grue Standard - Grúa standard**

<b>Bracci stabilizzatori extra estensibili idraulici</b> Hydraulic extra extensible outrigger booms - Bras de stabilisation hydrauliques extra-extensibles - Brazos estabilizadores hidráulicos extra extensibles	<b>mm. 5540</b>
<b>Angolo di rotazione</b> Slewing angle - Angle de rotation - Giro	<b>400°</b>
<b>Tiranti di ancoraggio 42CrM04</b> Tie rods for anchorage - Tirants d'ancrage - Tirantes de fijación	<b>n° 8 M30x2</b>
<b>Portata raccomandata</b> Recommended oil flow - Débit recommandé - Caudal requerido	<b>l/min. 50</b>
<b>Capacità del serbatoio</b> Tank capacity - Capacité du réservoir - Capacidad del depósito de aceite	<b>lt. 160</b>
<b>Pressione massima</b> Rated pressure - Pression maxi - Presión máxima	<b>bar 340</b>

**HC 370-R BC A4**

**Massa della gru senza olio nel serbatoio**  
Overhang crane without oil in the tank **Kg. 4330**  
Poids de la grue sans huile dans le réservoir  
Peso de la grúa sin aceite en el depósito

**Momento di sollevamento massimo**  
Maximum lifting moment - Moment de levage maxi **tm 32,93**  
Momento de elevación máxima

**Sbraccio oleodinamico**  
Maximum hydraulic reach - Déport hydraulique - Alcance hidráulico

**Orizzontale** Horizontal - Horizontal - Horizontal **m. 10,97**  
**Verticale** Vertical - Vertical - Vertical **m. 14,47**

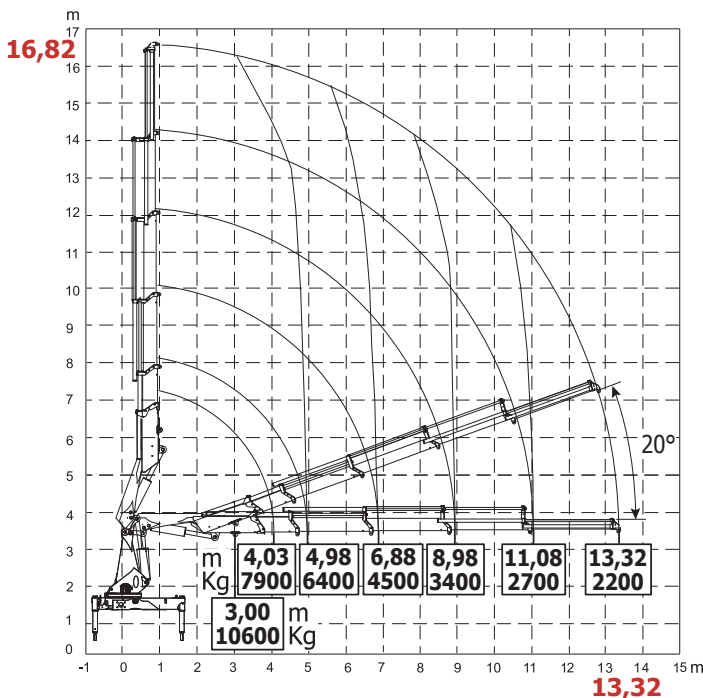
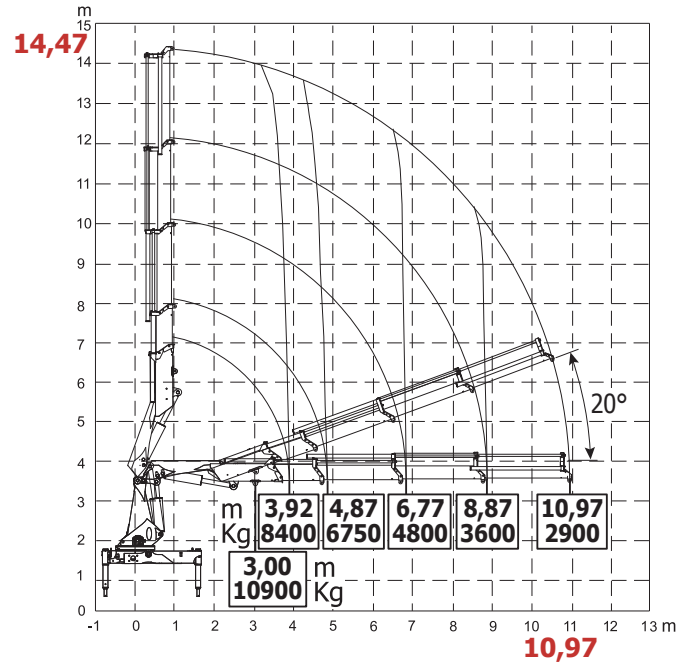

**HC 370-R BC A5**

**Massa della gru senza olio nel serbatoio**  
Overhang crane without oil in the tank **Kg. 4530**  
Poids de la grue sans huile dans le réservoir  
Peso de la grúa sin aceite en el depósito

**Momento di sollevamento massimo**  
Maximum lifting moment - Moment de levage maxi **tm 31,84**  
Momento de elevación máxima

**Sbraccio oleodinamico**  
Maximum hydraulic reach - Déport hydraulique - Alcance hidráulico

**Orizzontale** Horizontal - Horizontal - Horizontal **m. 13,32**  
**Verticale** Vertical - Vertical - Vertical **m. 16,82**

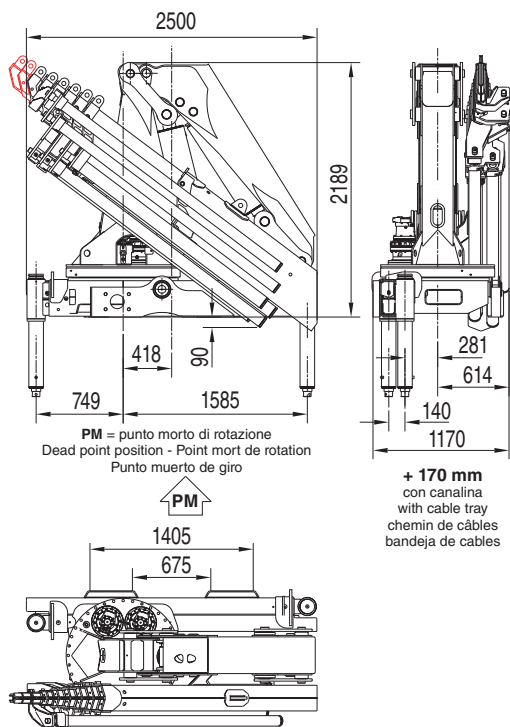

**GRU STANDARD Std Crane - Grue Standard - Grua standard**

**Bracci stabilizzatori extra estensibili idraulici**  
 Hydraulic extra extensible outrigger booms - Bras de stabilisation hydrauliques extra-extensibles - Brazos estabilizadores hidráulicos extra extensibles **mm. 5540**

**Angolo di rotazione**  
 Slewing angle - Angle de rotation - Giro **400°**

**Tiranti di ancoraggio 42CrM04**  
 Tie rods for anchorage - Tirants d'ancrage - Tirantes de fijación **n° 8 M30x2**

**Portata raccomandata**  
 Recommended oil flow - Débit recommandé - Caudal requerido **l/min. 50**

**Capacità del serbatoio**  
 Tank capacity - Capacité du réservoir - Capacidad del depósito de aceite **lt. 160**

**Pressione massima**  
 Rated pressure - Pression maxi - Presión máxima **bar 340**

**HC 370-R BC A6**

**Massa della gru senza olio nel serbatoio**  
 Overhang crane without oil in the tank **Kg. 4730**  
 Poids de la grue sans huile dans le réservoir  
 Peso de la grua sin aceite en el depósito

**Momento di sollevamento massimo**  
 Maximum lifting moment - Moment de levage maxi **tm 31,92**  
 Momento de elevación máxima

**Sbraccio oleodinamico**  
 Maximum hydraulic reach - Déport hydraulique - Alcance hidráulico

**Orizzontale** Horizontal - Horizontal - Horizontal **m. 15,67**  
**Verticale** Vertical - Vertical - Vertical **m. 19,17**

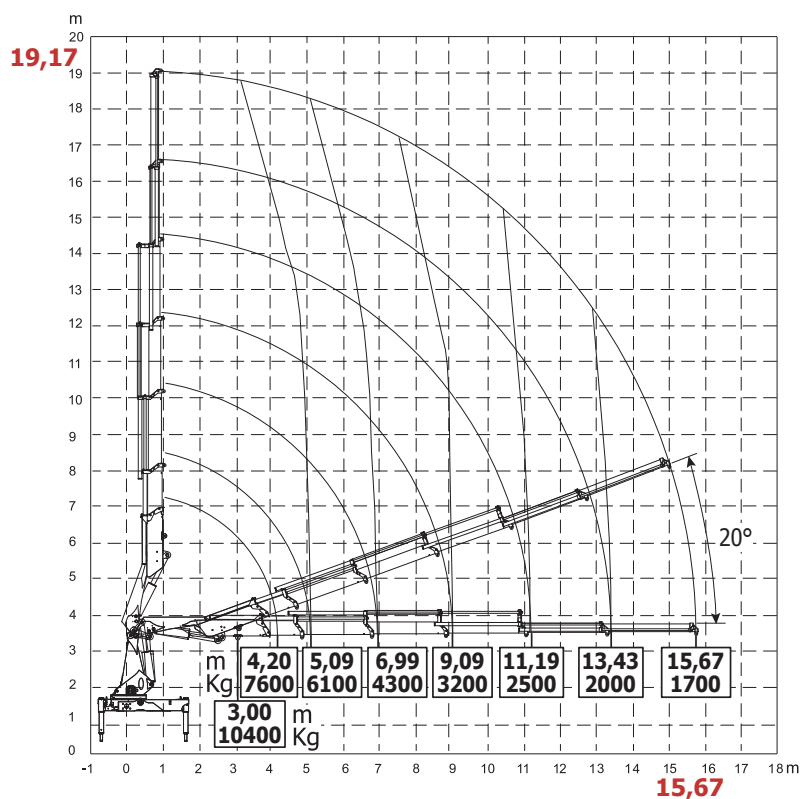

TUTTI I DATI TECNICI POSSONO ESSERE CAMBIATI SENZA PRAVAVISO - ALL TECHNICAL DATA CAN BE CHANGED WITHOUT NOTICE  
 TOUS LES DONNEES TECHNIQUES PEUVENT ENTRE MODIFIEES SANS PRAVAVIS - TODOS LOS DATOS TECNICOS PUEDEN SER CAMBIADOS SIN AVISO

**HC INDUSTRIE S.R.L.**  
 Via Luciano Romagnoli, 1  
 42023 Cadelbosco di Sopra Reggio Emilia, Z.I. La Madonnina (RE)  
 Phone +39.0522.911729 - Fax +39.0522.404040  
 Email: commerciale@hcindustrie.com - Website: www.hcindustrie.com

